

Swing Check Valve Class 600

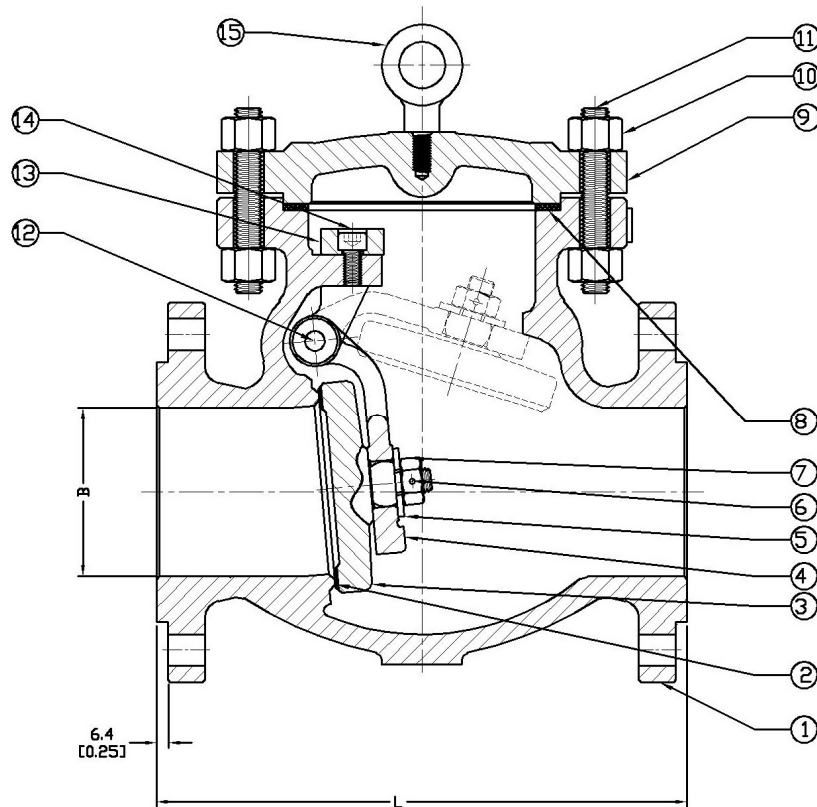

Standards:

Face to Face Dimensions: ANSI B16.10
 End Flange Dimensions: ANSI B16.5
 Basic Design: ASME B16.34
 Test Standard: API 598

MATERIAL LIST

| NO. | Part Name | ASTM Specification (Specs – Grades/Types) | |
|-----|-----------------------------|---|--------------|
| | | A351 | A351 |
| | | CF8 (304) | CF8M (316) |
| 1 | Body | A351-CF8 | A351-CF8M |
| 2 | Seat-Integral | A351-CF8 | A351-CF8M |
| 3 | Disc | A182-F304 | A182-F316 |
| 4 | Swing Arm | A351-CF8 | A351-CF8M |
| 5 | Washer | A276-316 | A276-316 |
| 6 | Pin | A276-316 | A276-316 |
| 7 | Hex Nut | A194-8 | A194-8 |
| 8 | Gasket | 304/Graphite | 316/Graphite |
| 9 | Cover | A351-CF8 | A351-CF8M |
| 10 | Body Nut | A194-8A | A194-8A |
| 11 | Body Stud | A193-B8M | A193-B8M |
| 12 | Hinge Pin | A193-B8M | A193-B8M |
| 13 | Hinge Plate | A351-CF8 | A351-CF8M |
| 14 | Bolt | A194-8A | A194-8A |
| 15 | Lifting Eye (6" and larger) | Carbon Steel | Carbon Steel |

NOTE: Seat rings on valves less than 2 NPS are swedged into the valve body.

DIMENSIONS AND WEIGHTS

| Size | NPS | 1/2 | 3/4 | 1 | 1-1/2 | 2 | 2-1/2 | 3 | 4 | 6 | 8 | 10 | 12 |
|---------|-----|-------|-------|-------|-------|-------|-------|-------|-------|-------|-------|-------|-------|
| L (RF) | In | 6.50 | 7.50 | 8.50 | 9.50 | 11.50 | 13.00 | 14.00 | 17.00 | 22.00 | 26.00 | 31.00 | 33.00 |
| | Mm | 165 | 190 | 216 | 241 | 292 | 330 | 356 | 432 | 559 | 660 | 787 | 838 |
| L (RTJ) | In | 6.42 | 7.50 | 8.50 | 9.50 | 11.63 | 13.13 | 14.13 | 17.13 | 22.13 | 26.13 | 31.13 | 33.13 |
| | Mm | 163 | 190 | 216 | 241 | 295 | 333 | 359 | 435 | 562 | 664 | 791 | 841 |
| L (BW) | In | 6.50 | 7.50 | 8.50 | 9.50 | 11.50 | 13.00 | 14.00 | 17.00 | 22.00 | 26.00 | 31.00 | 33.00 |
| | Mm | 165 | 190 | 216 | 241 | 292 | 330 | 356 | 432 | 559 | 660 | 787 | 838 |
| B | In | 0.50 | 0.75 | 1.00 | 1.50 | 2.00 | 2.50 | 3.00 | 4.00 | 5.98 | 7.87 | 9.76 | 11.73 |
| | Mm | 12.7 | 19.1 | 25.4 | 38.1 | 51 | 63.5 | 76 | 102 | 152 | 200 | 248 | 298 |
| WT | LB | 12.79 | 20.94 | 22.93 | 36.50 | 48.50 | 72.75 | 90.50 | 159.0 | 348.0 | | | |
| | KG | 5.8 | 9.5 | 10.4 | 16.5 | 22.0 | 33.0 | 41.0 | 72.0 | 158.0 | | | |