

## Check Valve Class 600

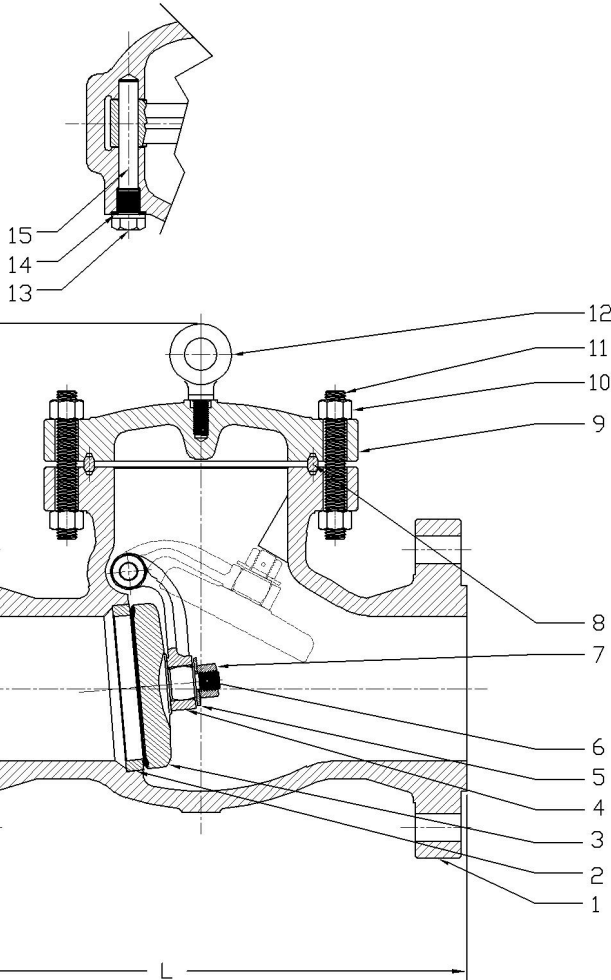

**Standards:**

Face to Face Dimensions: ANSI B16.10  
 End Flange Dimensions: ANSI B16.5  
 26" ≥ MSS SP-44  
 Or ASME B16.47  
 Basic Design: ANSI B16.34  
 Wall Thickness Per: API 600  
 Test Standard: API 598

**MATERIAL LIST**

NO.	Part Name	ASTM Specification (Specs – Grades/Types)				
		A 216	A 352	A 217	A 351	
		WCB	LCC	WC6	WC5	CF8M
1	Body	A216-WCB	A352-LCC	A217-WC6	A217-C5	A351-CF8M
2	Seat Ring	A105	A350-LF2	A182-F11	A182-F11	
	Seat Ring Surface	13CR, HF (CoCr-A), 316, 304, or Monel				
3	Disc	A105	A350-LF2	A182-F11	A182-F11	A182-316
	Disc Seating Surface	13CR, HF (CoCr-A), 316, 304, or Monel				
4	Swing Arm	A 216-WCB	A 352-LCC	A217-WC6	A 217-WC5	A 351-CF8M
5	Washer	ASTM A276 Gr. 316				
6	Pin	ASTM A276 Gr. 316				
7	Disc Nut	A194 Gr. 8				
8	Gasket	F5				
9	Bonnet	A216-WCB	A352-LCC	A217-WC6	A217-C5	A351-CF8M
10	Body Nut	A 193-B7	A 320-L7	A 193-B7	A 193-B16	A 193-B8
11	Body Stud	A 193-B7	A 320-L7	A 193-B7	A 193-B16	A 193-B8
12	Eyebolt	A181				
13	Hinge Pin Bolt	A 193-B7	A 320-L7	A 193-B7	A 193-B16	A 193-B8
14	Gasket	08F				
15	Hinge Pin	A276-410	A276-410	A276-410	A276-410	A276-316

**DIMENSIONS AND WEIGHTS**

Size	NPS	2	2-1/2	3	4	6	8	10	12	14	16	18	20	24	26	28	30	32	36
L (RF)	In	11.50	13.00	14.00	17.00	22.00	26.00	31.00	33.00	35.00	39.00	43.00	47.00	55.00	57.00	63.00	65.00	70.00	82.00
	Mm	292	330	356	432	559	660	787	838	889	990	1092	1194	1397	1448	1600	1651	1778	2083
L (RTJ)	In	11.63	13.13	14.13	17.13	22.13	26.13	31.13	33.13	35.13	39.13	43.13	47.25	55.38	55.38	63.50	65.50	70.62	82.62
	Mm	295	333	359	435	562	664	791	841	892	994	1096	1200	1407	1407	1613	1664	1794	2099
L (BW)	In	11.50	13.00	14.00	17.00	22.00	26.00	31.00	33.00	35.00	39.00	43.00	47.00	55.00	57.00	63.00	65.00	70.00	82.00
	Mm	292	330	356	432	559	660	787	838	889	990	1092	1194	1397	1448	1600	1651	1778	2083
ØB	In	2.00	2.50	3.00	4.00	6.00	7.87	9.75	11.75	12.87	14.88	17.25	19.25	22.00	25.25	27.25	29.25	31.25	35.25
	Mm	51	64	76	102	152	200	248	298	327	375	438	489	559	641	692	743	794	896
H	In	7.36	8.50	10.94	12.44	15.75	17.01	19.02	20.00	22.52	25.98	28.74	31.50	35.43	40.00	41.97	45.98	48.03	51.97
	Mm	187	216	278	316	400	432	483	508	572	660	730	800	900	1016	1066	1168	1220	1320
WT	KG	52	63	75	122	227	346	628	796	892	1200	1600	2420	3150	3800	4600	5500	6250	7800
	LB	115	139	165	269	500	763	1384.5	1755	1966.5	2645	3527	5335	6944	8377.5	10141	12125	13778	17196

(713) 673-2073 – Fax (713) 673-4641 - Toll Free (866) GO-BERIC (462-3742)

www.bericvalves.com