

Ball Check Valve Standard Port

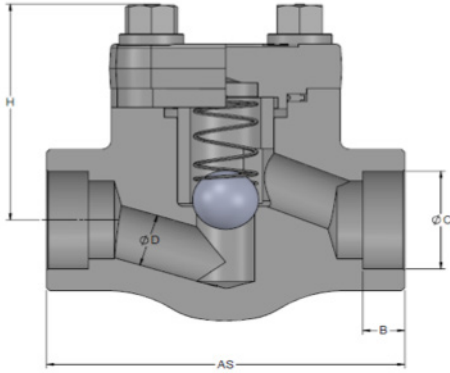

530 Series: Bolted Bonnet

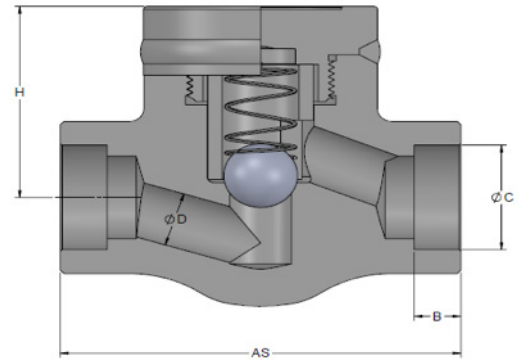
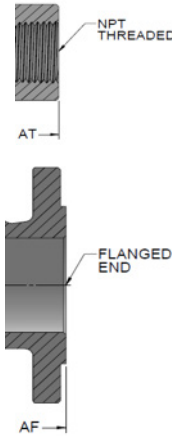

532 Series: Welded Bonnet

STANDARDS				
DESIGN:	API 602	TESTING:	API 598	
	MSS SP-118		CONNECTIONS:	NPT - ASME B1.20.1
	ASME B16.34			SW - ASME B16.11
	FACE TO FACE-ASME B16.10			BW- ASME B16.25
PRESSURE CLASS:	NPT, SW & BW - 800, 1500	FLANGED - ASME B16.5		
	FLANGED - 150, 300, 600, 1500			

STANDARD MATERIAL LIST							
Part Name	A105	LF2	F5	F9	F11	F22	F316/F316L
Ball	A276-440C						A182-F316
Guide	A276-410						A276-316
Spring	A276-316						

SIZE		DIMENSIONS										WGT.(lb/kg)								
		AT/AS 800	AF-150	AF-300	AF-600	B (Min)	C (Min)	D(Min)- NPT/SW	D(Min)-RF	H-530 (150)	H-530 (300)	H-530 (600)	H-530 (800)	H-532 (800)	150 (530)	300 (530)	600 (530)	800 (530)	800 (532)	
1/4	Inch	3.11	/	/	/	0.37	0.56	0.27	/	/	/	/	2.28	1.97	/	/	/	/	3.53	3.09
	mm	79.0	/	/	/	9.5	14.2	6.8	/	/	/	/	58.0	50.0	/	/	/	/	1.6	1.4
3/8	Inch	3.11	/	/	/	0.37	0.69	0.27	/	/	/	/	2.28	1.97	/	/	/	/	3.53	3.09
	mm	79.0	/	/	/	9.5	17.6	6.8	/	/	/	/	58.0	50.0	/	/	/	/	1.6	1.4
1/2	Inch	3.11	4.25	5.98	6.50	0.39	0.86	0.37	0.37	2.20	2.20	2.28	2.28	1.97	4.85	6.17	7.05	3.31	2.87	
	mm	79.0	108.0	152.0	165.0	10.0	21.8	9.5	9.5	56.0	56.0	58.0	58.0	50.0	2.2	2.8	3.2	1.5	1.3	
3/4	Inch	3.62	4.61	7.01	7.48	0.51	1.07	0.49	0.49	2.20	2.28	2.28	2.28	2.05	5.95	9.26	9.92	3.75	3.31	
	mm	92.0	117.0	178.0	190.0	13.0	27.2	12.5	12.5	56.0	58.0	58.0	58.0	52.0	2.7	4.2	4.5	1.7	1.5	
1	Inch	4.37	5.00	7.99	8.50	0.51	1.33	0.69	0.69	2.95	2.95	2.95	2.95	2.76	9.70	13.89	15.21	5.95	5.51	
	mm	111.0	127.0	203.0	216.0	13.0	33.9	17.5	17.5	75.0	75.0	75.0	75.0	70.0	4.4	6.3	6.9	2.7	2.5	
1-1/4	Inch	4.72	5.51	8.50	9.02	0.51	1.68	0.93	0.93	3.35	3.35	3.35	3.35	3.23	13.67	18.74	27.12	8.60	9.26	
	mm	120.0	140.0	216.0	229.0	13.0	42.7	23.5	23.5	85.0	85.0	85.0	85.0	82.0	6.2	8.5	12.3	3.9	4.2	
1-1/2	Inch	5.98	6.50	9.02	9.49	0.51	1.92	1.12	1.12	3.82	3.82	3.82	3.82	3.78	17.64	25.79	28.66	11.68	12.57	
	mm	152.0	165.0	229.0	241.0	13.0	48.8	28.5	28.5	97.0	97.0	97.0	97.0	96.0	8.0	11.7	13.0	5.3	5.7	
2	Inch	6.77	7.99	10.51	11.50	0.65	2.41	1.44	1.44	4.65	4.65	4.53	4.25	4.33	30.42	39.24	43.65	17.20	21.16	
	mm	172.0	203.0	267.0	292.0	16.5	61.2	36.5	36.5	118.0	118.0	115.0	108.0	110.0	13.8	17.8	19.8	7.8	9.6	

SIZE		DIMENSIONS-1500						WGT.(lb/kg)		
		AT/AS (530)	AT/AS (532)	B (Min)	C (Min)	D(Min)-NPT/SW	H (530)	H (532)	NPT/SW (530)	NPT/SW (532)
1/2	Inch	4.37	4.37	0.39	0.86	0.37	2.95	2.76	6.39	5.95
	mm	111.0	111.0	10.0	21.8	9.5	75.0	70.0	2.9	2.7
3/4	Inch	4.37	4.37	0.51	1.07	0.49	2.95	2.76	6.39	5.95
	mm	111.0	111.0	13.0	27.2	12.5	75.0	70.0	2.9	2.7
1	Inch	4.72	4.72	0.51	1.33	0.69	3.35	3.23	9.04	9.48
	mm	120.0	120.0	13.0	33.9	17.5	85.0	82.0	4.1	4.3
1-1/4	Inch	5.98	5.98	0.51	1.68	0.93	3.82	3.78	12.79	12.35
	mm	152.0	152.0	13.0	42.7	23.5	97.0	96.0	5.8	5.6
1-1/2	Inch	6.77	6.77	0.51	1.92	1.12	4.25	4.37	19.40	18.08
	mm	172.0	172.0	13.0	48.8	28.5	108.0	111.0	8.8	8.2
2	Inch	8.66	8.66	0.65	2.41	1.44	5.20	4.53	36.38	29.76
	mm	220.0	220.0	16.5	61.2	36.5	132.0	115.0	16.5	13.5