

Bellows Seal Gate Valve Standard Port

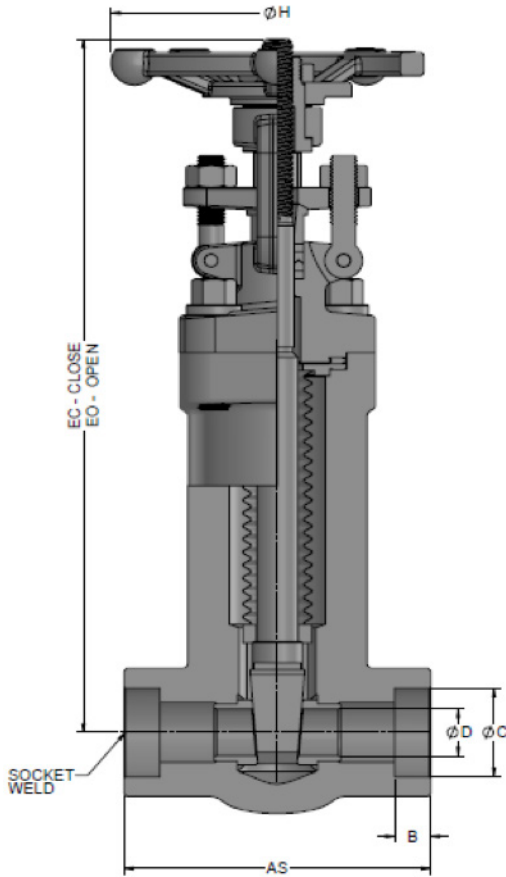

501 Series: Bolted Bonnet

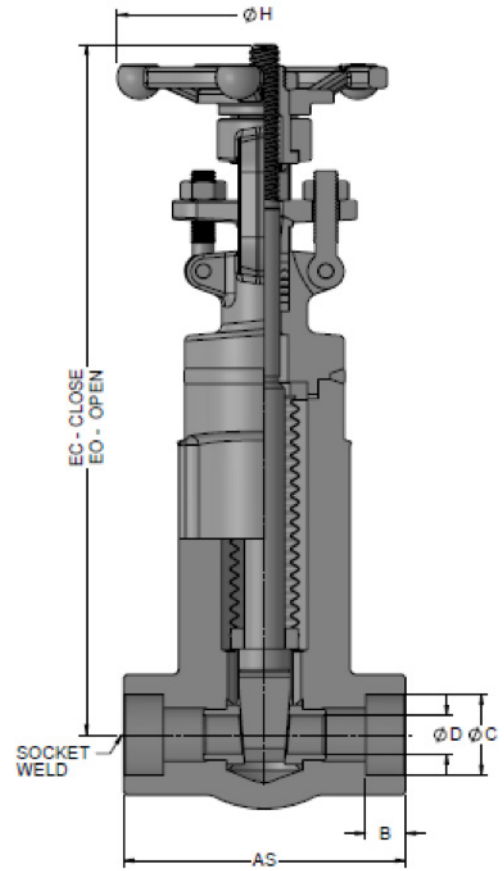

505 Series: Welded Bonnet

STANDARDS	
DESIGN:	API 602 ASME B16.34
TESTING:	API 598
PRESSURE CLASS:	NPT, SW & BW - 800
CONNECTIONS:	NPT - ASME B1.20.1 SW - ASME B16.11 BW - ASME B16.25

STANDARD MATERIAL LIST	
Part Name	SPECIFICATION
Bellows	F316L / F321

DIMENSIONS											WGT.(lb/kg)	
SIZE		AT/AS 800	B (Min)	C (Min)	D(Min)-NPT/ SW	EC-NPT/SW (501)	EO-NPT/SW (501)	EC-NPT/SW (505)	EO-NPT/SW (505)	H	NPT/SW (501)	NPT/SW (505)
1/4	Inch	3.11	0.39	0.56	0.30	8.90	9.49	9.17	9.76	3.94	7.28	7.05
	mm	79.0	10.0	14.2	7.5	226.0	241.0	233.0	248.0	100.0	3.3	3.2
3/8	Inch	3.11	0.39	0.69	0.39	8.90	9.49	9.17	9.76	3.94	7.05	6.83
	mm	79.0	10.0	17.6	10	226.0	241.0	233.0	248.0	100.0	3.2	3.1
1/2	Inch	3.11	0.39	0.86	0.51	8.90	9.49	9.17	9.76	3.94	6.83	6.61
	mm	79.0	10.0	21.8	13.0	226.0	241.0	233.0	248.0	100.0	3.1	3.0
3/4	Inch	3.62	0.51	1.07	0.51	8.90	9.49	9.17	9.76	3.94	7.28	7.05
	mm	92.0	13.0	27.2	13.0	226.0	241.0	233.0	248.0	100.0	3.3	3.2
1	Inch	4.37	0.51	1.33	0.71	10.39	11.22	10.71	11.50	4.72	11.90	11.68
	mm	111.0	13.0	33.9	18.0	264.0	285.0	272.0	292.0	120.0	5.4	5.3
1-1/2	Inch	4.72	0.51	1.92	1.14	13.94	15.12	13.94	15.16	6.30	22.49	22.05
	mm	120.0	13.0	48.8	29.0	354.0	384.0	354.0	385.0	160.0	10.2	10.0
2	Inch	5.51	0.65	2.41	1.44	16.14	17.72	16.14	17.72	8.66	32.63	32.19
	mm	140.0	16.5	61.2	36.5	410.0	450.0	410.0	450.0	220.0	14.8	14.6