

Gate Valve Class 300

Standards:

Face to Face Dimensions: ANSI B16.10

End Flange Dimensions: ANSI B16.5
26" ≥ MSS SP-44
Or API 605

Basic Design: API 600

Test Standard: API 603 (316 Valves)
API 598

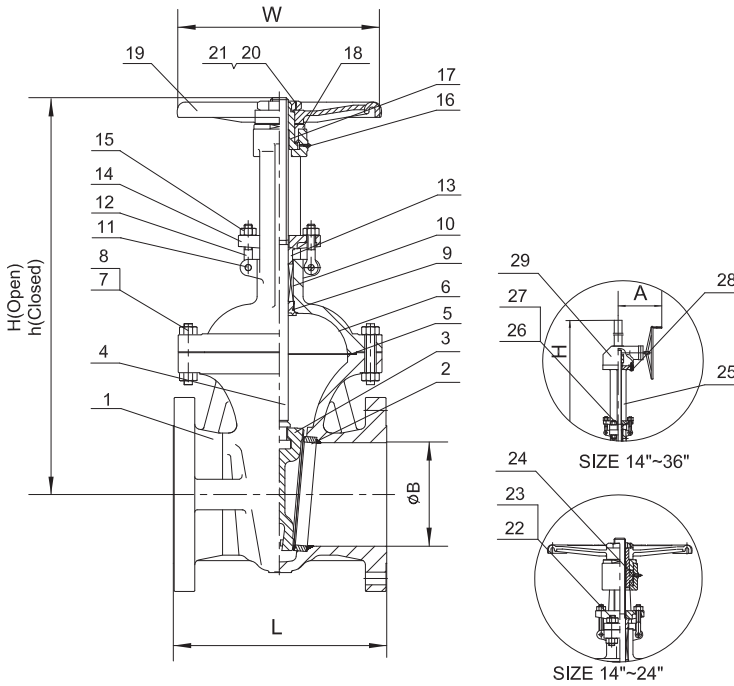

NO.		Part Name	ASTM Specification (Specs - Grades/Types)				
			A 216	A 352	A 217		A 351
		WCB	LCC	WC6	C5	CF8M	
1	Body	A 216-WCB	A 352-LCC	A217-WC6	A 217-C5	A 351-CF8M	
2	Seat Ring	A 105, LF2, 316, or 304					
	Seat Ring Surface	13CR, HF (CoCr-A), 316, 304, or Monel					
3	Gate	A 216 - WCB	A 352-LCC	A217-WC6	A 217-C5	A 351-CF8M	
	Gate Seating Surface	13CR, HF (CoCr-A), 316, 304, or Monel					
4	Stem	13CR, 316, 304, 17-4PH, or Monel					
5	Gasket	Graphite Jacketed Stainless Steel					
6	Bonnet	A 216 - WCB	A 352-LCC	A217-WC6	A 217-C5	A 351-CF8M	
7	Bonnet Bolt Nut	A 194-2H	A 194-4	A 194-2H	A 194-4	A 194-8	
8	Bonnet Bolt	A 193-B7	A 320-L7	A 193-B7	A 193-B16	A 193-B8	
9	Bonnet Bushing	13CR, 316, or 304					
10	Packing	Braided Graphite & Die Formed Graphite Ring					
11	Eye Bolt Pins	Carbon Steel				A 276 Type 316	
12	Gland Eye Bolts	A 193-B7	A 320-L7	A 193-B7		A 193-B8	
13	Gland	13CR, 316, or 304					
14	Gland Flange	A 216 - WCB	A 352-LCC	A217-WC6	A 217-C5	A 351-CF8M	
15	Eye Bolt Nut	A 194-2H	A 194-7	A 194-2H		A 194-8	
16	Grease Nipple	Carbon Steel				A 276 Type 316	
17	Yoke Sleeve	A 439 Gr. D2C					
18	Retaining Nut	Carbon Steel				A 276 Type 316	
19	Handwheel	Malleable Iron					
20	Handwheel Nut	Carbon Steel				A 276 Type 316	
21	Screw	Carbon Steel					
22	Yoke Pad Bolts	A 193-B7				A 276 Type 316	
23	Yoke Pad Bolt Nuts	A 194-2H				A 276 Type 316	
24	Bearing	Carbon Steel					
25	Yoke	A 216 - WCB	A 352-LCC	A217-WC6	A 217-C5	A 351-CF8M	
26	Yoke Pad Bolt	A 193-B7	A 320-L7	A 193-B7	A 193-B16	A 193-B8	
27	Yoke Pad Bolt Nuts	A 194-2H	A 194-4	A 194-2H	A 194-4	A 194-8	
28	Stud	Carbon Steel					
29	Gear	Carbon Steel					

DIMENSIONS AND WEIGHTS																		
Size	NPS	2	2-1/2	3	4	5	6	8	10	12	14	16	18	20	24	26	28	30
L (RF)	In	8.50	9.50	11.12	12.00	15.00	15.88	16.50	18.00	19.75	30.00	33.00	36.00	39.00	45.00	49.00	53.00	55.00
	Mm	216	241	283	305	381	403	419	457	502	762	838	914	991	1143	1244	1346	1397
L (RTJ)	In	9.12	10.12	11.75	12.62	15.62	16.50	17.12	18.62	20.37	30.62	33.62	36.62	39.75	45.88	49.88	53.88	56.00
	Mm	232	257	298	321	397	419	435	473	518	778	854	930	1010	1165	1266	1368	1422
L (BW)	In	8.50	9.50	11.12	12.00	15.00	15.88	16.50	18.00	19.75	30.00	33.00	36.00	39.00	45.00	49.00	53.00	55.00
	Mm	216	241	283	305	381	403	419	457	502	762	838	914	991	1143	1244	1346	1397
A	In								9.45	9.45	14.17	14.17	14.17	16.18	16.18	23.62	23.62	23.62
	Mm								240.0	240.0	360.0	360.0	360.0	411.0	411.0	600.0	600.0	600.0
ØB	In	2	3	3	4	5	6	8	10	12	13	15	17	19	23	25	27	29
	Mm	51	64	76	102	127	152	203	254	305	337	387	432	489	591	641	692	743
H	In	16.70	18.10	21.00	24.20	26.10	31.30	39.90	48.50	57.00	64.80	72.50	76.50	84.80	100.50	108.30	122.10	130.70
	Mm	424	460	535	615	662	795	1012	1231	1450	1645	1841	1943	2154	2553	2750	3100	3320
W	In	8	10	10	10	12	14	16	18	20	22	25	25	28	28	28*	35*	35*
	Mm	200	250	250	250	300	350	400	450	500	560	640	640	720	720	720*	900*	900*
WT	KG	24	44	52	76	94	146	218	352	472	694	1080	1235	1655	2320	3100	3893.0	4930.0
	LB	52.9	97.00	114.6	167.5	207.2	321.9	480.6	776.0	1040.6	1530.0	2381.0	2722.7	3648.6	5114.7	6834.3	8582.5	10868.7

*GEAR OPERATOR RECOMMENDED

(713) 673-2073 - Fax (713) 673-4641 - Toll Free (866) GO-BERIC (462-3742)

www.bericvalves.com

Rev. 010111

Copyright 2011

Page 2GT