

Globe Valve Class 900

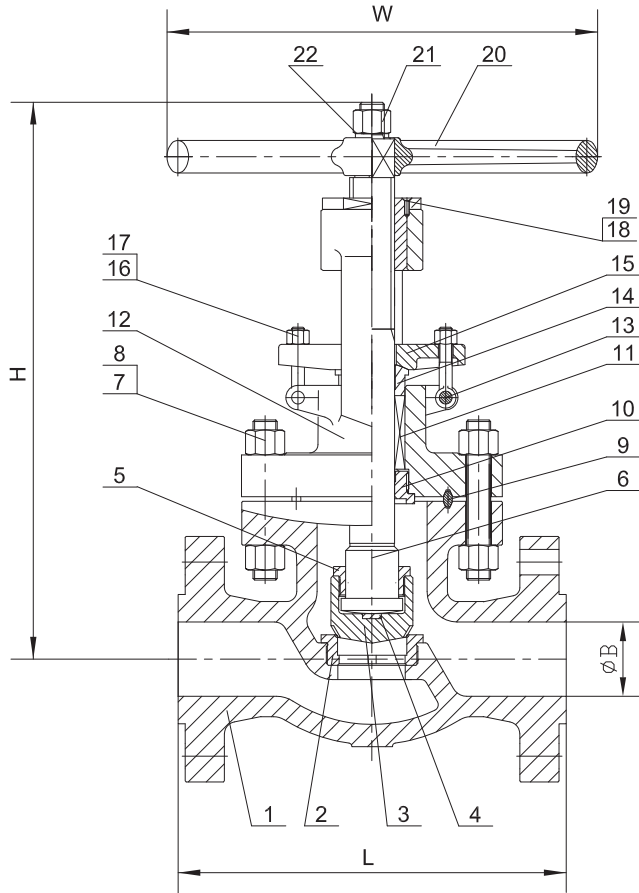

NO.		ASTM Specification (Specs - Grades/Types)				
		A 216	A 352	A 217	A 351	
		WCB	LCC	WC6	C5	CF8M
1	Body	A 216-WCB	A 352-LCC	A 217-WC6	A 217-C5	A 351-CF8M
2	Seat Ring	A 105, LF2, 316, or 304				
	Seat Ring Surface	13CR, HF (CoCr-A), 316, 304, or Monel				
3	Disc	A 216 - WCB	A 352-LCC	A 217-WC6	A 217-C5	A 351-CF8M
	Disc Seating Surface	13CR, HF (CoCr-A), 316, 304, or Monel				
4	Disc Thrust Plate	13CR, 316, OR 304				
5	Disc Nut	13CR, 316, OR 304				
6	Stem	13CR, 316, 304, 17-4PH, or Monel				
7	Bonnet Bolt Nut	A 194-2H	A 194-4	A 194-2H	A 194-4	A 194-8
8	Bonnet Bolt	A 193-B7	A 320-L7	A 193-B7	A 193-B16	A 193-B8
9	Gasket	Ring Joint - Iron				
10	Bonnet Bushing	13CR, 316, OR 304				
11	Gland Packing	Braided Graphite & Die Formed Graphite Ring				
12	Bonnet	A 216-WCB	A 352-LCC	A 217-WC6	A 217-C5	A 351-CF8M
13	Eye Bolt Pins	13CR, 316, or 304				
14	Gland	13CR, 316, or 304				
15	Gland Flange	A 216-WCB	A 352-LCC	A 217-WC6	A 217-C5	A 351-CF8M
16	Gland Eye Bolts	A 193-B7	A 320-L7	A 193-B7	A 193-B16	A 193-B8
17	Eye Bolt Nuts	A 194-2H	A 194-4	A 194-2H	A 194-4	A 194-8
18	Yoke Sleeve	ASTM A 439 Gr. D2C				
19	Screw	Carbon Steel				
20	Handwheel	Malleable Iron				
21	Handwheel Nut	Carbon Steel				
22	Backing Ring	Carbon Steel				

Standards:

Face to Face Dimensions: ANSI B16.10
 End Flange Dimensions: ANSI B16.5
 26" ≥ MSS SP-44
 Or API 605
 B16.34 & BS1873
 Basic Design:
 Test Standard: API 598

DIMENSIONS AND WEIGHTS									
Size	NPS	2	2-1/2	3	4	6	8	10	12
L	In	14.50	16.50	15.00	18.00	24.00	29.00	33.00	38.00
(RF)	Mm	368	419	381	457	610	737	838	965
L	In	14.63	16.63	15.13	18.13	24.13	29.13	33.15	38.11
(RTJ)	Mm	371	422	384	460	613	740	842	968
L	In	14.50	16.50	15.00	18.00	24.00	29.00	33.00	38.00
(BW)	Mm	368	419	381	457	610	737	838	965
ØB	In	1.87	2.25	2.87	3.89	5.75	7.50	9.38	11.12
	Mm	48	57	73	99	146	190	238	292
H	In	22.63	26.00	28.13	31.50	40.00	45.13	50.31	55.55
	Mm	600	660	665	800	1015	1145	1278	1411
W	In	14	16	16	18	22	25	25	28
	Mm	350	400	400	450	560	640	640	720
WT	KG	87.0	130.0	122.0	182.0	434.0	730.0	1231.0	1568.0
	LB	191.80	286.60	268.96	401.24	956.80	1609.36	2713.86	3456.81

(713) 673-2073 - Fax (713) 673-4641 - Toll Free (866) GO-BERIC (462-3742)

www.bericvalves.com

Rev. 010111

Copyright 2011

Page 4GL