

Piston Check Valve Standard Port

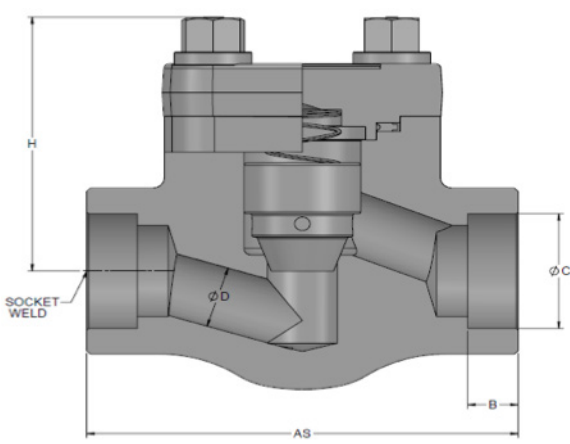

503 Series: Bolted Bonnet

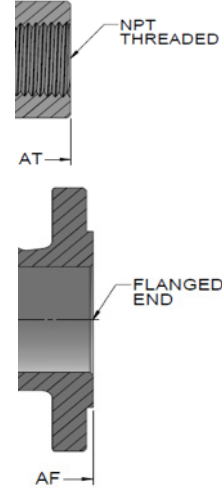

507 Series: Welded Bonnet

STANDARDS				
DESIGN:	API 602	TESTING:	API 598	
	ASME B16.34		CONNECTIONS:	NPT - ASME B1.20.1
	FACE-TO-FACE - ASME B16.10			SW - ASME B16.11
PRESSURE CLASS:	NPT, SW & BW - 800, 1500		BW- ASME B16.25	
	FLANGED - 150, 300, 600, 1500		FLANGED - ASME B16.5	

DIMENSIONS														WGT.(lb/kg)										
SIZE		AT/AS 800	AF - 150	AF - 300	AF - 600	B (Min)	C (Min)	D (Min)- NPT/ SW	D (Min)- RF	H-NPT/ SW (503)	H-NPT/ SW (507)	H-RF (150)	H-RF (300)	H-RF (600)	150 (503)	150 (507)	300 (503)	300 (507)	600 (503)	600 (507)	800 (503)	800 (507)		
1/4	Inch	3.11	/	/	/	0.39	0.56	0.27	/	2.28	1.97	/	/	/	/	/	/	/	/	/	/	/	3.31	2.87
	mm	79.0	/	/	/	10.0	14.2	6.8	/	58.0	50.0	/	/	/	/	/	/	/	/	/	/	/	1.5	1.3
3/8	Inch	3.11	/	/	/	0.39	0.69	0.27	/	2.28	1.97	/	/	/	/	/	/	/	/	/	/	/	3.31	2.87
	mm	79.0	/	/	/	10.0	17.6	6.8	/	58.0	50.0	/	/	/	/	/	/	/	/	/	/	/	1.5	1.3
1/2	Inch	3.11	4.25	5.98	6.50	0.39	0.86	0.37	0.37	2.28	1.97	2.20	2.20	2.28	4.85	7.94	6.17	8.16	7.05	8.82	3.09	2.65	3.09	2.65
	mm	79.0	108.0	152.0	165.0	10.0	21.8	9.5	9.5	58.0	50.0	56.0	56.0	58.0	2.2	3.6	2.8	3.7	3.2	4.0	1.4	1.2	1.4	1.2
3/4	Inch	3.62	4.61	7.01	7.48	0.51	1.07	0.49	0.49	2.28	2.05	2.20	2.28	2.28	5.95	10.14	9.26	10.58	9.92	12.79	3.31	3.31	3.31	3.31
	mm	92.0	117.0	178.0	190.0	13.0	27.2	12.5	12.5	58.0	52.0	56.0	58.0	58.0	2.7	4.6	4.2	4.8	4.5	5.8	1.5	1.5	1.5	1.5
1	Inch	4.37	5.00	7.99	8.50	0.51	1.33	0.69	0.69	2.95	2.76	2.95	2.95	2.95	9.70	18.74	13.89	19.40	15.21	20.94	5.95	5.73	5.95	5.73
	mm	111.0	127.0	203.0	216.0	13.0	33.9	17.5	17.5	75.0	70.0	75.0	75.0	75.0	4.4	8.5	6.3	8.8	6.9	9.5	2.7	2.6	2.7	2.6
1-1/4	Inch	4.72	5.51	8.50	9.02	0.51	1.68	0.93	0.93	3.35	3.23	3.35	3.35	3.35	14.33	20.28	17.86	21.16	22.93	22.93	8.60	9.26	8.60	9.26
	mm	120.0	140.0	216.0	229.0	13.0	42.7	23.5	23.5	85.0	82.0	85.0	85.0	85.0	6.5	9.2	8.1	9.6	10.4	10.4	3.9	4.2	3.9	4.2
1-1/2	Inch	5.98	6.50	9.02	9.49	0.51	1.92	1.12	1.12	3.82	3.78	3.82	3.82	3.82	17.64	27.56	25.79	30.20	28.66	34.39	11.68	12.35	11.68	12.35
	mm	152.0	165.0	229.0	241.0	13.0	48.8	28.5	28.5	97.0	96.0	97.0	97.0	97.0	8.0	12.5	11.7	13.7	13.0	15.6	5.3	5.6	5.3	5.6
2	Inch	6.77	7.99	10.51	11.50	0.65	2.41	1.44	1.44	4.25	4.33	4.65	4.65	4.53	30.42	32.63	38.58	39.24	43.65	54.01	17.20	20.50	17.20	20.50
	mm	172.0	203.0	267.0	292.0	16.5	61.2	36.5	36.5	108.0	110.0	118.0	118.0	115.0	13.8	14.8	17.5	17.8	19.8	24.5	7.8	9.3	7.8	9.3

DIMENSIONS-1500												WGT.(lb/kg)			
SIZE		AT/AS (503)	AT/AS (507)	AF (503)	B (Min)	C (Min)	D (Min)	D (Min)	H-NPT/SW (503)	H-NPT/SW (507)	H-RF (503)	NPT/SW (503)	NPT/SW(507)	RF (503)	
1/2	Inch	4.37	4.37	8.50	0.39	0.86	0.37	0.37	2.95	2.76	2.95	6.39	6.61	13.89	
	mm	111.0	111.0	216.0	10.0	21.8	9.5	9.5	75.0	70.0	75.0	2.9	3.0	6.3	
3/4	Inch	4.37	4.37	9.02	0.51	1.07	0.49	0.49	2.95	2.76	2.95	6.17	6.39	18.96	
	mm	111.0	111.0	229.0	13.0	27.2	12.5	12.5	75.0	70.0	75.0	2.8	2.9	8.6	
1	Inch	4.72	4.72	10.00	0.51	1.33	0.69	0.69	3.35	3.23	3.35	9.04	11.24	28.66	
	mm	120.0	120.0	254.0	13.0	33.9	17.5	17.5	85.0	82.0	85.0	4.1	5.1	13.0	
1-1/4	Inch	5.98	5.98	/	0.51	1.68	0.93	0.93	3.82	3.78	/	12.79	13.45	/	
	mm	152.0	152.0	/	13.0	42.7	23.5	23.5	97.0	96.0	/	5.8	6.1	/	
1-1/2	Inch	6.77	6.77	12.01	0.51	1.92	1.12	1.12	4.25	4.33	5.31	19.40	23.81	56.66	
	mm	172.0	172.0	305.0	13.0	48.8	28.5	28.5	108.0	110.0	135.0	8.8	10.8	25.7	
2	Inch	8.66	8.66	14.49	0.65	2.41	1.44	1.44	5.20	4.53	6.50	36.38	33.51	94.58	
	mm	220.0	220.0	368.0	16.5	61.2	36.5	36.5	132.0	115.0	165.0	16.5	15.2	42.9	