

Piston Check Valve Full Port

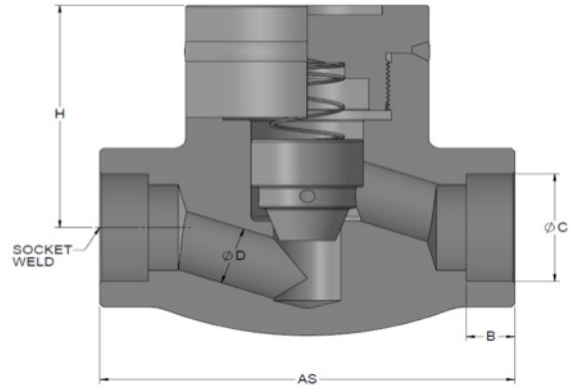
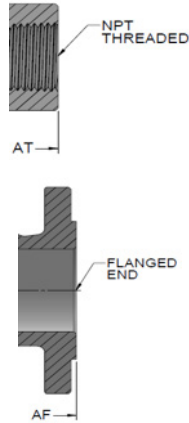
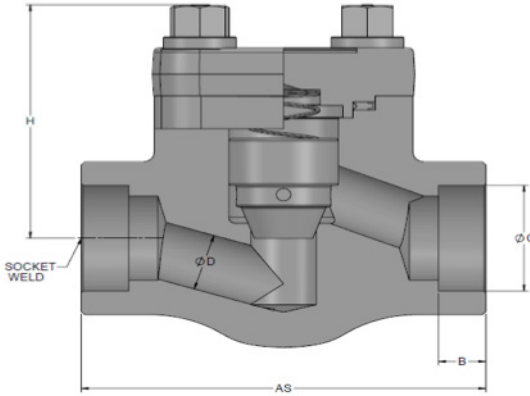

523 Series: Bolted Bonnet

517 Series: Welded Bonnet

STANDARDS				
DESIGN:	API 602	TESTING:	API 598	
	MSS SP-118		CONNECTIONS:	NPT - ASME B1.20.1
	ASME B16.34			SW - ASME B16.11
PRESSURE CLASS:	FACE TO FACE-ASME B16.10	BW- ASME B16.25	FLANGED - ASME B16.5	
	NPT, SW & BW - 800, 1500			
	SW & BW - 1500			
	FLANGED - 150, 300, 600, 1500			

DIMENSIONS											WGWT.(lb/kg)									
SIZE		AT/AS 800	AF - 150	AF - 300	AF - 600	B (Min)	C (Min)	D(Min)- NPT/SW	D(Min)-RF	H-RF/ NPT/SW (523)	H-RF/ NPT/SW (517)	150 (523)	150 (517)	300 (523)	300 (517)	600 (523)	600 (517)	800 (523)	800 (517)	
1/4	Inch	3.62	/	/	/	0.39	0.56	0.27	/	2.40	2.05	/	/	/	/	/	/	/	3.97	3.75
	mm	92.0	/	/	/	10.0	14.2	6.8	/	61.0	52.0	/	/	/	/	/	/	/	1.8	1.7
3/8	Inch	3.62	/	/	/	0.39	0.69	0.37	/	2.40	2.05	/	/	/	/	/	/	/	3.97	3.75
	mm	92.0	/	/	/	10.0	17.6	9.5	/	61.0	52.0	/	/	/	/	/	/	/	1.8	1.7
1/2	Inch	3.62	4.25	5.98	6.50	0.39	0.86	0.49	0.49	2.28	2.05	10.14	9.92	10.58	10.36	12.79	12.35	3.31	3.53	
	mm	92.0	108.0	152.0	165.0	10.0	21.8	12.5	12.5	58.0	52.0	4.6	4.5	4.8	4.7	5.8	5.6	1.5	1.6	
3/4	Inch	4.37	4.61	7.01	7.48	0.51	1.07	0.69	0.69	2.95	2.76	18.74	18.30	19.40	19.40	20.94	20.72	8.38	7.05	
	mm	111.0	117.0	178.0	190.0	13.0	27.2	17.5	17.5	75.0	70.0	8.5	8.3	8.8	8.8	9.5	9.4	3.8	3.2	
1	Inch	4.72	5.00	7.99	8.50	0.51	1.33	0.89	0.89	3.35	3.23	20.28	19.84	21.16	20.94	22.93	22.93	13.01	11.68	
	mm	120.0	127.0	203.0	216.0	13.0	33.9	22.5	22.5	85.0	82.0	9.2	9.0	9.6	9.5	10.4	10.4	5.9	5.3	
1-1/4	Inch	5.98	5.51	8.50	9.02	0.51	1.68	1.12	1.12	3.82	3.74	27.56	26.46	30.20	29.76	34.39	34.83	16.75	15.43	
	mm	152.0	140.0	216.0	229.0	13.0	42.7	28.5	28.5	97.0	95.0	12.5	12.0	13.7	13.5	15.6	15.8	7.6	7.0	
1-1/2	Inch	6.77	6.50	9.02	9.49	0.51	1.92	1.40	1.40	4.25	4.33	32.63	31.97	39.24	37.48	54.01	52.91	22.71	22.05	
	mm	172.0	165.0	229.0	241.0	13.0	48.8	35.5	35.5	108.0	110.0	14.8	14.5	17.8	17.0	24.5	24.0	10.3	10.0	
2	Inch	8.66	7.99	10.51	11.50	0.65	2.41	1.75	1.75	5.71	4.53	37.04	35.27	43.65	41.89	58.42	57.32	38.14	34.83	
	mm	220.0	203.0	267.0	292.0	16.5	61.2	44.5	44.5	145.0	115.0	16.8	16.0	19.8	19.0	26.5	26.0	17.3	15.8	

DIMENSIONS-1500								WGWT.(lb/kg)		
SIZE		AS/AT (523)	AS/AT (517)	B (Min)	C (Min)	D-NPT/SW (Min)	H-NPT/SW (523)	H-NPT/SW (517)	NPT/SW (523)	NPT/SW (517)
1/2	Inch	4.37	4.37	0.39	0.86	0.37	2.95	2.76	6.39	7.05
	mm	111.0	111.0	10.0	21.8	9.5	75.0	70.0	2.9	3.2
3/4	Inch	4.72	4.72	0.51	1.07	0.59	3.35	3.23	9.26	11.68
	mm	120.0	120.0	13.0	27.2	15.0	85.0	82.0	4.2	5.3
1	Inch	5.98	5.98	0.51	1.33	0.79	3.82	3.74	13.01	15.87
	mm	152.0	152.0	13.0	33.9	20.0	97.0	95.0	5.9	7.2
1-1/4	Inch	6.77	6.77	0.51	1.68	1.02	4.25	4.33	19.62	23.59
	mm	172.0	172.0	13.0	42.7	26.0	108.0	110.0	8.9	10.7
1-1/2	Inch	6.77	6.77	0.51	1.92	1.12	4.25	4.33	19.40	23.59
	mm	172.0	172.0	13.0	48.8	28.5	108.0	110.0	8.8	10.7
2	Inch	8.66	8.66	0.65	2.41	1.38	5.20	4.53	36.38	34.83
	mm	220.0	220.0	16.5	61.2	35.0	132.0	115.0	16.5	15.8