

Swing Check Valve Full Port

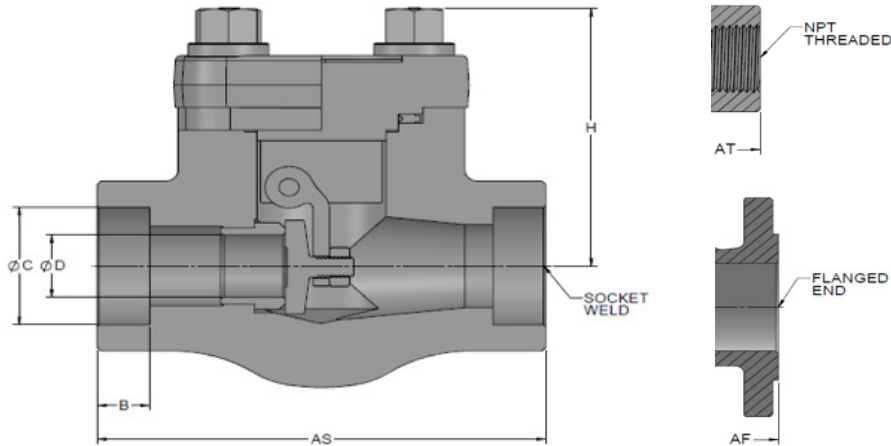

514 Series: Bolted Bonnet

STANDARDS				
DESIGN:	API 602	TESTING:	API 598	
	MSS SP-118		CONNECTIONS:	NPT - ASME B1.20.1
	ASME B16.34			SW - ASME B16.11
	FACE TO FACE-ASME B16.10			BW- ASME B16.25
PRESSURE CLASS:	NPT, SW & BW - 800, 1500		FLANGED - ASME B16.5	
	FLANGED - 150, 300, 600, 1500			

DIMENSIONS											WGT.(lb/kg)			
SIZE		AT/AS 800	AF-150	AF-300	AF-600	B [Min]	C [Min]	D[Min]-NPT/ SW	D[Min]-RF	H	150 [514]	300 [514]	600 [514]	800 [514]
1/4	Inch	3.11	/	/	/	0.39	0.56	0.30	/	2.40	/	/	/	3.97
	mm	79.0	/	/	/	10.0	14.2	7.5	/	61.0	/	/	/	1.8
3/8	Inch	3.11	/	/	/	0.39	0.69	0.39	/	2.40	/	/	/	3.97
	mm	79.0	/	/	/	10.0	17.6	10	/	61.0	/	/	/	1.8
1/2	Inch	3.11	4.25	5.98	6.50	0.39	0.86	0.51	0.51	2.28	10.14	10.58	12.79	2.87
	mm	79.0	108.0	152.0	165.0	10.0	21.8	13.0	13.0	58.0	4.6	4.8	5.8	1.3
3/4	Inch	4.37	4.61	7.01	7.48	0.51	1.07	0.71	0.71	2.95	18.74	19.40	20.94	5.95
	mm	111.0	117.0	178.0	190.0	13.0	27.2	18.0	18.0	75.0	8.5	8.8	9.5	2.7
1	Inch	4.72	5.00	8.50	8.50	0.51	1.33	0.94	0.94	3.27	20.28	21.16	22.93	8.16
	mm	120.0	127.0	216.0	216.0	13.0	33.9	24.0	24.0	83.0	9.2	9.6	10.4	3.7
1-1/4	Inch	4.72	5.51	9.02	9.02	0.51	1.68	1.14	1.14	3.70	27.56	30.20	34.39	9.70
	mm	120.0	140.0	229.0	229.0	13.0	42.7	29.0	29.0	94.0	12.5	13.7	15.6	4.4
1-1/2	Inch	5.51	6.50	9.49	9.49	0.51	1.92	1.44	1.44	4.21	32.63	39.24	54.01	14.33
	mm	140.0	165.0	241.0	241.0	13.0	48.8	36.5	36.5	107.0	14.8	17.8	24.5	6.5
2	Inch	6.30	7.99	10.51	11.50	0.65	2.41	1.81	1.81	5.12	42.77	59.30	74.07	28.66
	mm	160.0	203.0	267.0	292.0	16.5	61.2	46.0	46.0	130.0	19.4	26.9	33.6	13.0

DIMENSIONS-1500							WGT.(lb/kg)
SIZE		AT/AS [514]	B [Min]	C [Min]	D [Min]-NPT/SW	H	NPT/SW [514]
1/2	Inch	4.37	0.39	0.86	0.51	2.95	6.39
	mm	111.0	10.0	21.8	13.0	75.0	2.9
3/4	Inch	4.72	0.51	1.07	0.71	3.27	8.82
	mm	120.0	13.0	27.2	18.0	83.0	4.0
1	Inch	4.72	0.51	1.33	0.94	3.70	10.14
	mm	120.0	13.0	33.9	24.0	94.0	4.6
1-1/4	Inch	5.51	0.51	1.68	1.14	4.21	14.99
	mm	140.0	13.0	42.7	29.0	107.0	6.8
1-1/2	Inch	6.30	0.51	1.92	1.44	5.12	26.01
	mm	160.0	13.0	48.8	36.5	130.0	11.8
2	Inch	7.01	0.65	2.41	1.81	5.51	28.22
	mm	178.0	16.5	61.2	46.0	140.0	12.8