

Pressure Seal Gate Valve Class 900

Standards:

Face to Face Dimensions: ANSI B16.10
 End Flange Dimensions: ANSI B16.5
 Basic Design: ANSI B16.34
 *Conforms to the applicable requirements of API 600
 Test Standard: API 598

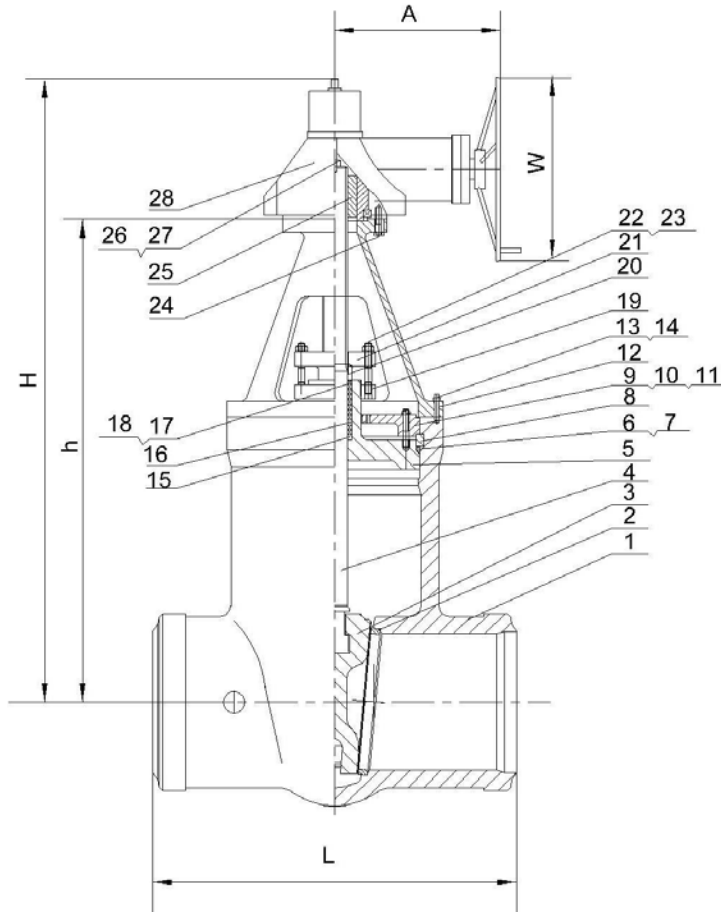

MATERIAL LIST		
NO.	Part Name	ASTM Specification (Specs - Grades/Types)
1	Body	A 216-WCB
2	Seat Ring	A 105/CoCr-A HF
	Seat Ring Surface	CoCr-A HF
3	Gate	A 216-WCB
	Gate Seating Surface	CoCr-A HF
4	Stem	A182 Gr. F6
5	Stuffing Box	A 216-WCB
6	Sealing Ring	A 276 Type 316
7	Pressure Ring	A 276 Type 420
8	Segment Ring	A 182 Gr. F6
9	Support Plate	A 216-WCB
10	Box-Plate Bolt	A 193 Gr. B7
11	Box-Plate Nut	A 194 Gr. 2H
12	Yoke	A 216-WCB
13	Box-Plate Bolt	A 193 Gr. B7
14	Box-Plate Nut	A 194 Gr. 2H
15	Packing Plate	A 276 Gr. 410
16	Lantern	A 276 Gr. 410
17	Wiper Ring	Braided Graphite
18	Packing	Flexible Graphite
19	Gland Flange Seat	A 216-WCB
20	Gland Follower	A 276 Gr. 410
21	Gland Flange	Carbon Steel
22	Gland Eyebolt	A 193 Gr. B7
23	Gland Eyebolt Nuts	A 194 Gr. 2H
24	Yoke-Gear Stud	Carbon Steel A 193 Gr. B7
25	Stem Nut	A 439 Gr. D2
26	Stem Indicator	A 276 Gr. 410
27	Stem Indicator Nut	Carbon Steel
28	Gear Protector	Carbon Steel

DIMENSIONS AND WEIGHTS											
Size	NPS	2	2-1/2	3	4	6	8	10	12	14	16
L	In	8.50	10.00	12.00	14.00	20.00	26.00	31.00	36.00	39.00	43.00
	Mm	216	254	304	355	508	660	787	914	991	1092
A	In	HW	HW	HW	HW	HW	HW	HW	HW	12.20	15.75
	Mm	HW	HW	HW	HW	HW	HW	HW	HW	310	400
B	In	1.87	2.25	2.87	3.87	5.35	6.75	8.44	10.12	11.25	12.75
	Mm	48	58	73	99	136	172	215	258	286	324
H	In	17.53	20.68	26.00	26.25	36.53	49.68	60.25	68.13	72.50	79.13
	Mm	445	525	660	666	928	1261	1530	1730	1842	2010
W	In	11.81	11.81	13.75	15.75	23.62	18.13	18.13	18.13	23.62	23.62
	Mm	300	300	350	400	600	460	460	460	600	600
WT	KG	50	74	90	110	195	505	745	1060	1410	1960
	LB	110.2	163.1	198.5	242.5	429.9	1113.3	1642.5	2336.9	3108.5	4321.0